



ISSN: 0067-2904

## Efficiency of Thematic Mapper Data for Detecting the Changes of Land Use -Land Cover in Mosul Lake and Surrounding Area Northern Iraq

Firas A. Hadi<sup>1</sup>, Walid A. Ahmad<sup>2</sup>, Faleh H. Mahmood<sup>3\*</sup>

<sup>1</sup>Department of Energy Science, College of Energy and Environmental Sciences, Al-Karkh University of Science, Baghdad, Iraq

<sup>2</sup>Department of Remote Sensing, College of Remote Sensing and Geophysics, Al-Karkh University of Science, Baghdad, Iraq

<sup>3</sup>Remote Sensing Unit, College of Science, University of Baghdad, Baghdad, Iraq

### Abstract

The study area lies in the northern part of Iraq, This study depends on one scene of Thematic Mapper (TM5) data of Landsat, these data are subset by using region of interest (ROI) file within the ERDAS 9.2 software. RS and GIS have been used as tools for detecting the desertification during the periods 1990-2000-2009 by using Normalized Difference Vegetation Index NDVI, Water Index WI and Barren Land Index BLI. The indicators of Desertification which used in this study for period 1990-2000 and 2000-2009 are represented by decrease the vegetation cover and increase water body and barren land.

**Keywords:** Desertification, NDVI, WI, BLI, GIS, Remote Sensing.

## كفاءة بيانات المتحسس TM في كشف ومراقبة تغيرات استخدامات الأراضي وغطائها لبحيرة الموصل والمناطق المحيطة بها شمال العراق

فiras عبد الرزاق هادي<sup>1</sup> ، وليد عبد المجيد أحمد<sup>2</sup> ، فالح حسن محمود<sup>3\*</sup>

<sup>1</sup>قسم علوم الطاقة ، كلية علوم الطاقة والبيئة ، جامعة الكرخ للعلوم ، بغداد ، العراق

<sup>2</sup>قسم التحسس النائي ، كلية التحسس النائي والجيوفيزياء ، جامعة الكرخ للعلوم ، بغداد ، العراق

<sup>3</sup>وحدة الاستشعار عن بع ، كلية العلوم ، جامعة بغداد ، بغداد ، العراق

### الخلاصة

تقع منطقة الدراسة في الجزء الشمالي من العراق، وتعتمد هذه الدراسة الحالية على مشهد واحد لبيانات المتحسس (TM5) والعائد للقرن الصناعي لاندسات، وهذه البيانات هي مجموعة فرعية مأخوذة من المشهد باعتماد طريقة الـ(ROI) باستخدام برنامج ERDAS . استخدمت تقنيات التحسس النائي و نظم المعلومات الجغرافية(GIS ) كأدوات لكشف ورصد التصحر واستخدامات الارض و تغيرات الغطاء الأرضي خلال الفترتين 1990-2000 و 2000-2009 باستخدام مؤشر الغطاء النباتي NDVI ومؤشر المياه WI ومؤشر الأراضي القاحلةBLI. وتتمثل مؤشرات التصحر التي استخدمت في هذه الدراسة للفترتين 1990-2000 و 2000-2009 في انخفاض الغطاء النباتي وزيادة الجسم المائي والأراضي القاحلة ضمن تلك الفترات.

### Introduction

The desertification phenomenon has received extensive attention in recent times; drought has caused extensive loss of life, livestock and environmental degradation. Although a number of recent studies, papers and reports from several countries beginning with comments on the role of drought in

\*Email:Faleh\_sine@yahoo.com

increased attention to the issue of desertification [1,2,3] that drought was not the first appearance of this phenomenon desertification and not the only reason for scientific interest in it. In fact, A. Aubreville, a French scientist, popularized the term desertification in his report as long ago as 1949, and other have discussed the phenomenon since the late 1950s [4,5, 6] .

In this research, we were focusing on changes in salinization, biomass density reduction, waterlogging, albedo increases. It is important to know that changing in vegetation cover lead to valuate (by many authors) the desertification rate at area of study. As the vegetation cover decreases, as the risks of wind and water erosion increased, on the other side the effect of solar radiation on bare soils are also increased [6, 7, 8].

### The Desertification in Iraq

About 90% of the area of Iraq is located within the area of Arid and semi-Arid climate; there are many reasons that helped the spread of desertification in Iraq. The most important reasons are [9, 10] :

- 1- Climate change: the most important of which is global warming, it is well known that a temperature in Iraq rises to the fifties in summer which increase the percentage of evaporation. Low rainfall, where no more than average rainfall 40 days per year in the south and 70 days per year in the north.

- 2- Drought, which is due largely to two things, first the lack of rain especially in last year's since 1991. The second reason for the drought is the lack of the waters of the Tigris and Euphrates, which had a negative impact on agriculture, and these two reasons in the basis for the spread of desertification.

- 3- Increase in dust storms in Iraq due to a lack of vegetation and lack of rain, and the other reason is the overgrazing of the shepherds.

- 4- Salinization of land in Iraq is the phenomenon of degradation or desertification of land in the Mesopotamian Plain as a result of the accumulation of dissolved salts such as chlorides and sodium sulfate, calcium and magnesium This accumulation of salts in soils reaches to the maximum extent in the surface layer of the soils and the roots, causing damage of plant that lead ultimately to its death.

### Location of the Study Area

The map area lies in the north part of Iraq the northwestern part near the Iraqi–Syrian international boundary and it is limited by the following coordinates. The main city which locates in the study area is Al-Mosul. The Tigris River drains the map area from northwest to southeast and consist Al-Mosul lakes (Figure -1)

Longitudes 42°00' 43°30'  
 Latitudes 36°00' 37°00'

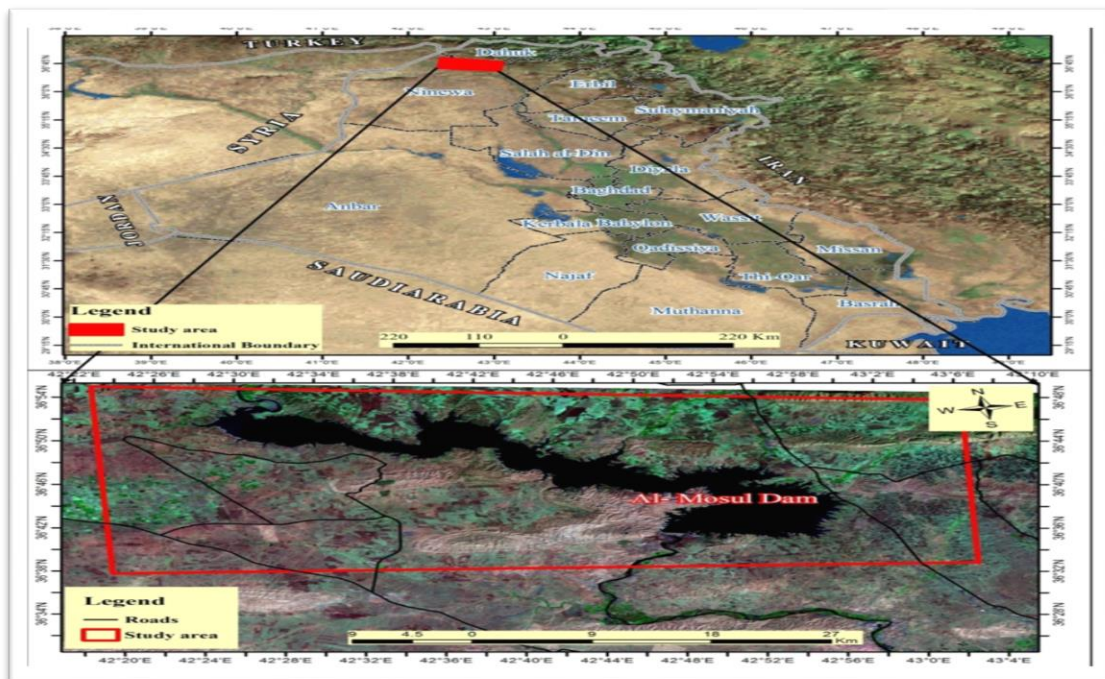

Figure -1. Area of Study

**Climate of the Study Area**

The highest percentage of rainfall recorded during the months of October to April. These data obtained from Duhok Meteorological Station. The total annual rainfall of 2009 is 346.9 mm and the mean annual Temperature is 20.9c° which are adopted to define the climate of the study area as in (Table-1)

**Methodology**

The procedure of the research consists of two stages as below:

*Data collection stage:* includes the study of previous works conducted in the region; preparation of Landsat satellite image and ancillary data such as digital elevation model (DEM), geological and topographic maps. *Initial office work stage:* includes data analysis and interpretation of satellite image and the preliminary results will be checked with the results of field work .Figure-2 shows methodology flowchart of the research.

**Table-1** Climate in the study area

Criteria		Jan.	Feb.	Mar.	Apr.	May	Jun.	Jul.	Aug.	Sep.	Oct.	Nov.	Dec.
Total of Rain / Depth mm		62.8	42.1	72.9	32.2	9.2	1.9	0.7	0	0.3	10.1	17.8	64.2
Humidity% Avg.	Max	79.6	71.1	66.1	60.5	41.1	26	23.9	26.5	31.6	43.4	58.4	76.4
	Min	40	39	23	31	27	17	17	19	25	29	40	34
Temperature C°	Max	13.2	15.8	19.6	25.2	33.9	40	43.7	43.1	37.9	30.9	22.6	15.4
	Min	3	3.2	6.6	11	16.1	21.4	25.5	24.2	19.2	13.8	7	4.7
	Air temp. Avg.	8	9.5	13.1	18.1	25	30.7	34.6	33.7	28.6	22.4	14.8	10.1
Wind Spd. (Max) m/s		1.3	1.4	1.8	2	2.3	2.1	2.1	1.9	1.5	1.2	0.8	1.2
Total of Pan evap. mm.		44	62.7	94.5	132.6	285.1	351.5	379.8	368	249.4	132.5	57.8	44.1

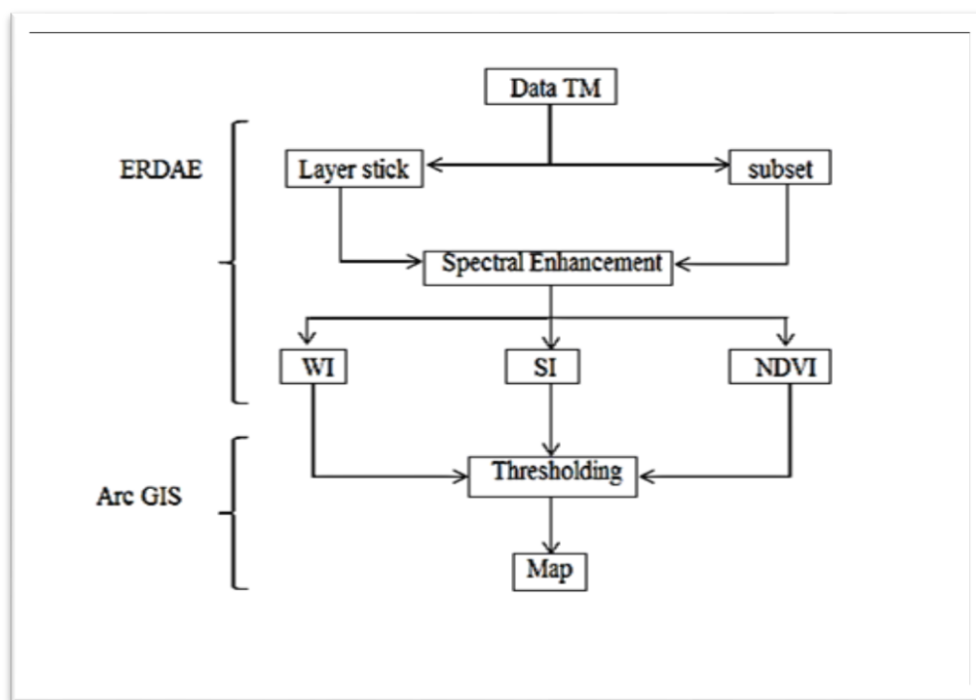

**Figure 2-**Flow chart of methodology in the present study.

**Normalized Difference Vegetation Index (NDVI)**

The normalized difference vegetation index (NDVI) has been widely used for remote sensing of vegetation for many years. This index uses radiances or reflectance from a red channel around 0.66 μm and a near-IR channel around 0.86 μm. The red channel is located in the strong chlorophyll absorption region, while the near-IR channel is located in the high reflectance plateau of vegetation



canopies. The two channels sense are very different depths through vegetation canopies. The NDVI is a calculation used to identify vegetation and its health through the levels of chlorophyll detected in the leaves. NDVI is calculated from the visible and near-infrared light reflected by vegetation [11, 12]. Healthy vegetation absorbs most of the incoming visible light, and reflects a large portion (about 25%) of the near infra-red (NIR) light, but a low portion in the red band (RED). Unhealthy or sparse vegetation reflects more visible light and less NIR light.

To apply the NDVI the following formula is used [13, 14]:

$$NDVI = (NIR - R \text{ Visible}) / (NIR + R \text{ Visible}) \dots\dots\dots (1)$$

Where

*NDVI*; Normalized Difference Vegetation Index,

*NIR*; Near Infra-Red channel;

*R*; Red band Visible

The NDVI is a common and widely used transformation for the enhancement of vegetation information [15]. It can be used for accurate description of land cover and vegetation classification [14, 16]. NDVI for the years 1990, 2000 and 2009 are shown respectively below in Figures-(3, 4, 5).

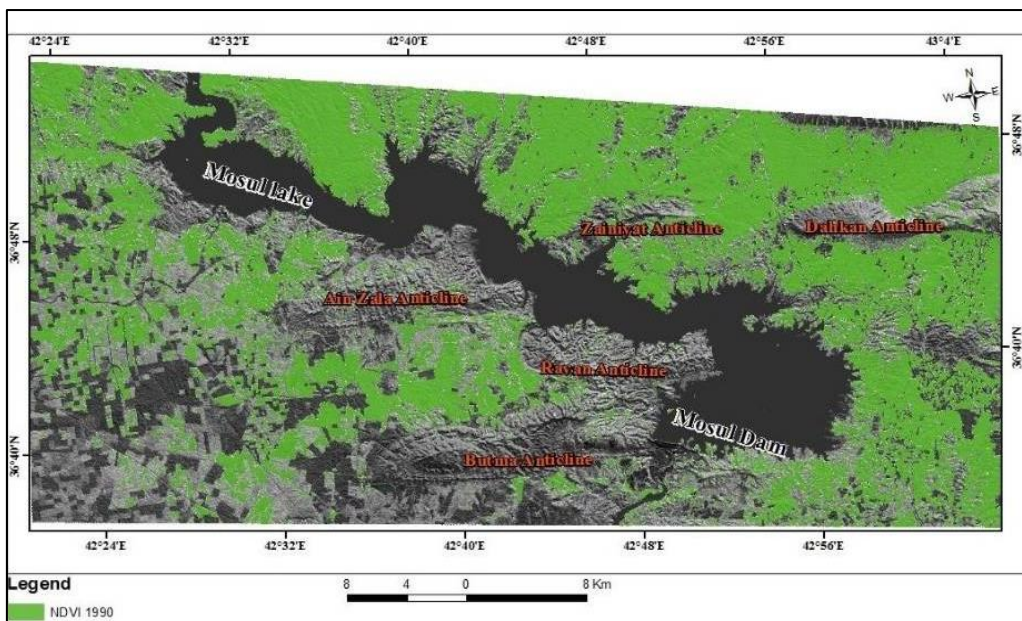

Figure 3-NDVI of 1990

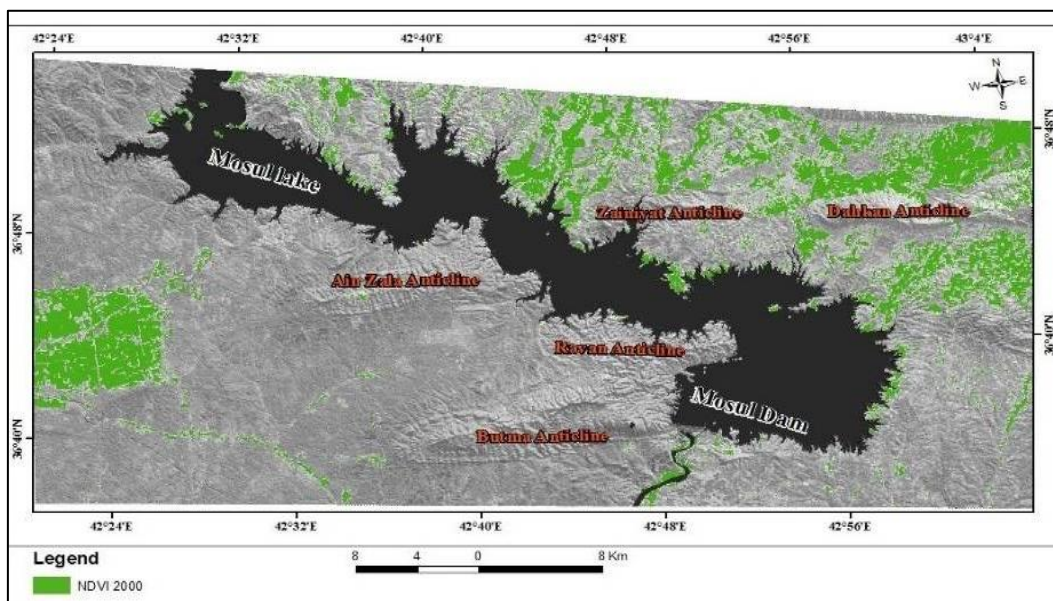

Figure 4-NDVI of 2000

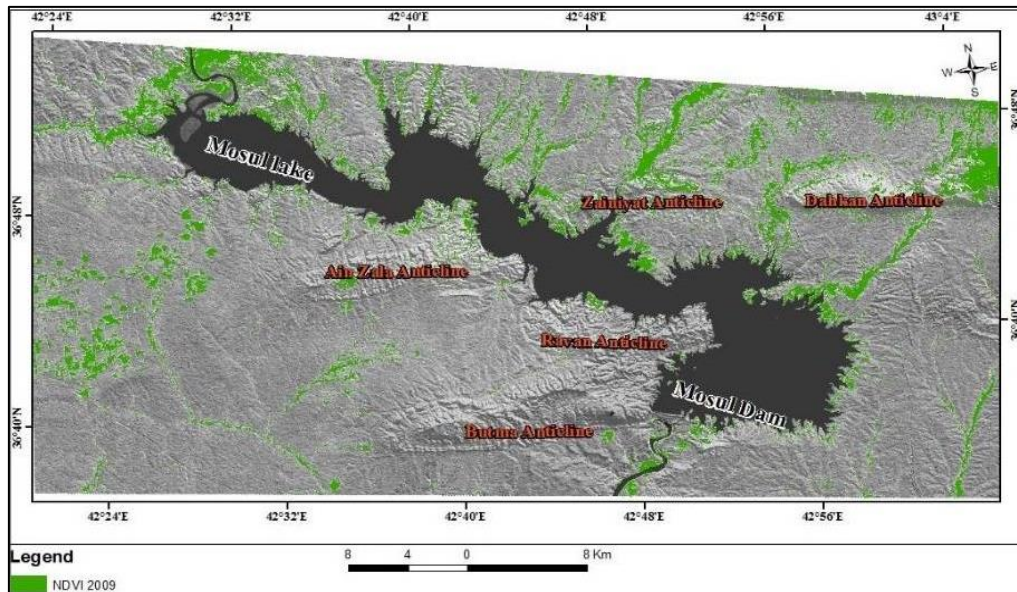

Figure 5-NDVI in 2009

**NDVI Change Detection**

The NDVI values range from -1.0 to 1.0. Vegetative cover have values greater than zero, Water bodies show negative values -1to 0 while Rock and bare soil have values from 0 to 0.02, vegetation has positive values (0.02 to 1.0) [11,17].

The quantification of NDVI is relative and not absolute. The classification accomplishing NDVI using GIS software depends on remotely sensed satellite data. Vegetated classification is based on threshold values to classify the NDVI for the years 1990, 2000 and 2009 respectively; as shown in attribute (Table-2). The classification system developed for vegetation in the study area is based on three categories: High, Moderate, and Low vegetation densities. The classified images are illustrated in Figures-(6, 7, 8). The distributions of NDVI percentage for periods1990, 2000, 2009 is demonstrated in Figure-9.

Table 2-NDVI Thresholding

<i>Land use - Land cover (NDVI)</i>	<i>Thresholding</i>		
	1990	2000	2009
High vegetation density	0.3635 - 0.7659	0.1349 - 0.7155	0.1901 - 0.6000
Moderate vegetation density	0.2696 - 0.3635	0.0922 - 0.1349	0.1001 - 0.1901
Low vegetation density	0.2226 - 0.2696	0.0603 - 0.0922	0.0325 - 0.1001



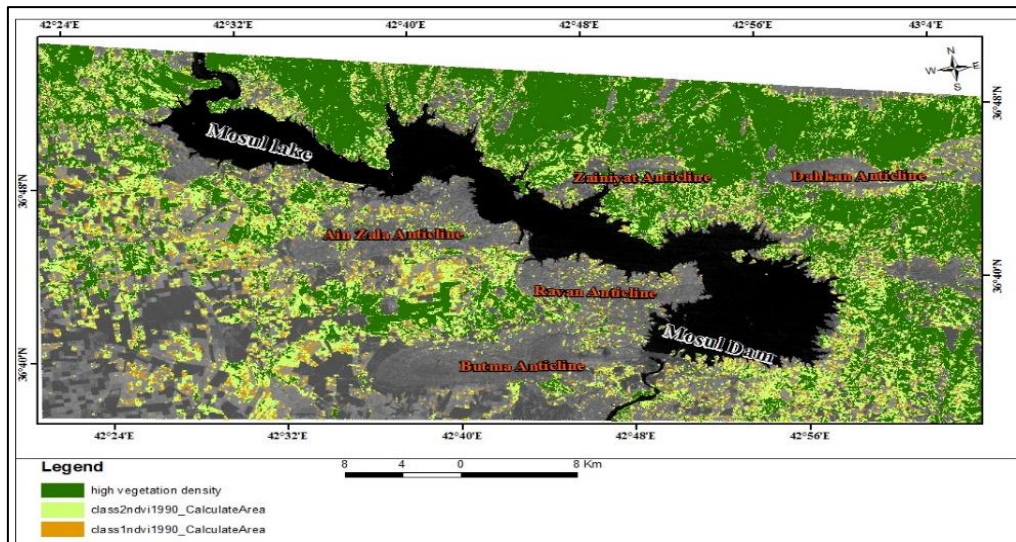

Figure 6-NDVI -1990

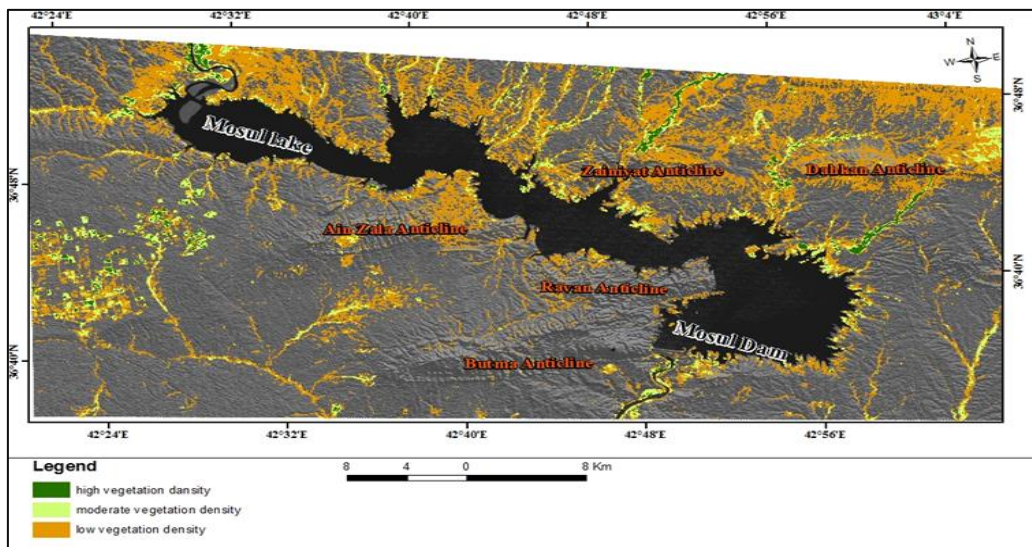

Figure 7-NDVI -2000

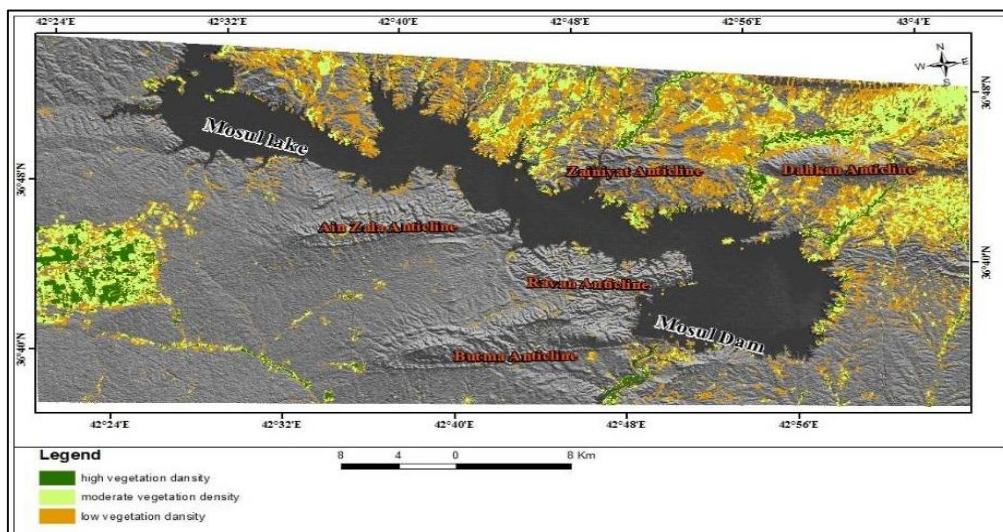

Figure 8-NDVI -2009

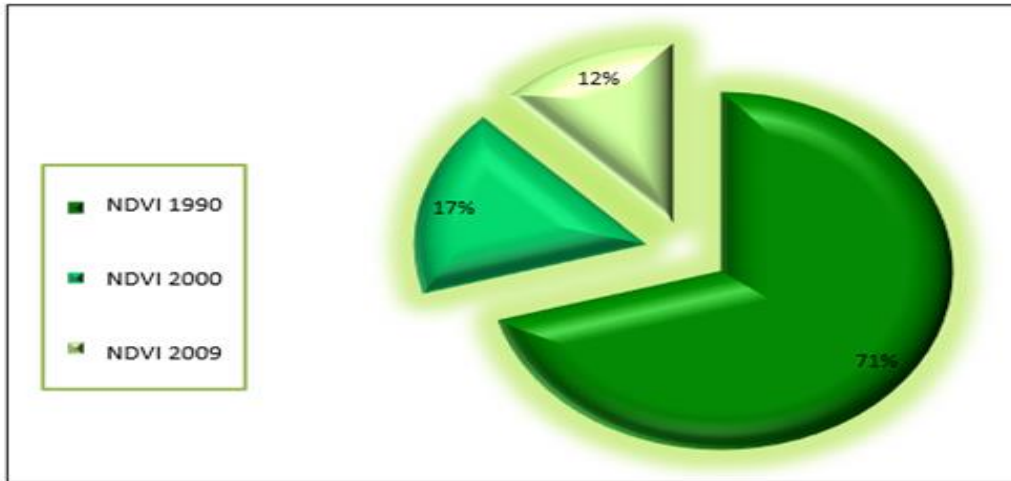

Figure 9-Percentage of NDVI

**Normalized Difference Water Index (NDWI)**

The Normalized Difference Water Index (NDWI) is a satellite-derived index from the Near-Infrared (NIR) and Short Wave Infrared (SWIR) channels. The SWIR reflectance reflects changes in both the vegetation water content and the spongy mesophyll structure in vegetation canopies, while the NIR reflectance is affected by leaf internal structure and leaf dry matter content but not by water content. The combination of the NIR with the SWIR removes variations induced by leaf internal structure and leaf dry matter content, improving the accuracy in retrieving the vegetation water content). The amount of water available in the internal leaf structure largely controls the spectral reflectance in the SWIR interval of the electromagnetic spectrum. SWIR reflectance is therefore negatively related to leaf water content [18].

The water index is usually calculated in order to monitor the water condition in the study site. Generally, water reflects in the visible light range only. As water has almost no reflection in the near infrared range, it is very distinctive among other surfaces. Thus, water surfaces will be clearly delimited as dark areas (low pixel values) in images recorded in the near infrared range. Equation (2) is used with the MSS sensor depending on bands 3 (NIR) and 4 (SWIR), with TM depending on bands 4 (NIR) and 5 (SWIR), [19].

$$NDWI = \frac{SWIR - NIR}{SWIR + NIR} \dots\dots (2)$$

Where

NDWI; Normalized Difference Water Index,

NIR; Near Infra-Red Band;

SWIR; Short Wave Infrared Band

Figures-(10, 11 and 12) show the NDWI images for the years 1990, 2000 and 2009 respectively.

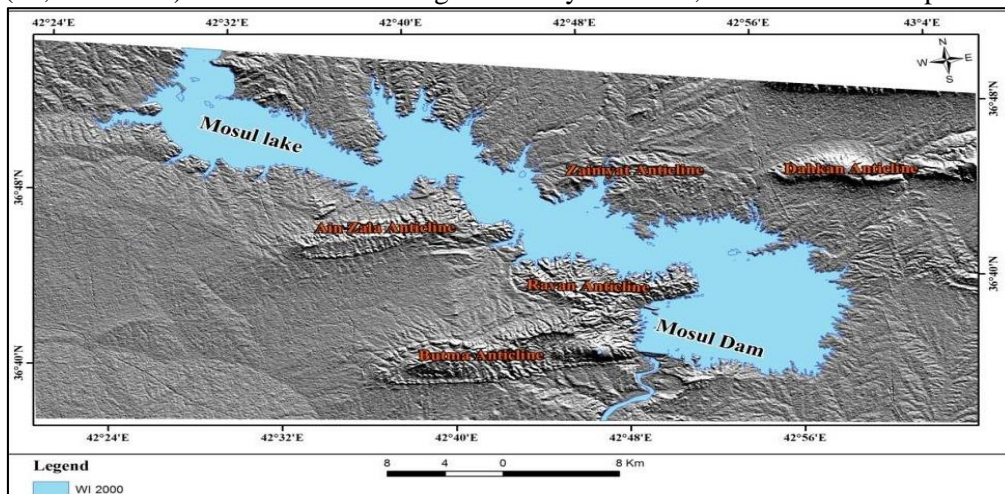

Figure 10-NDWI in 1990



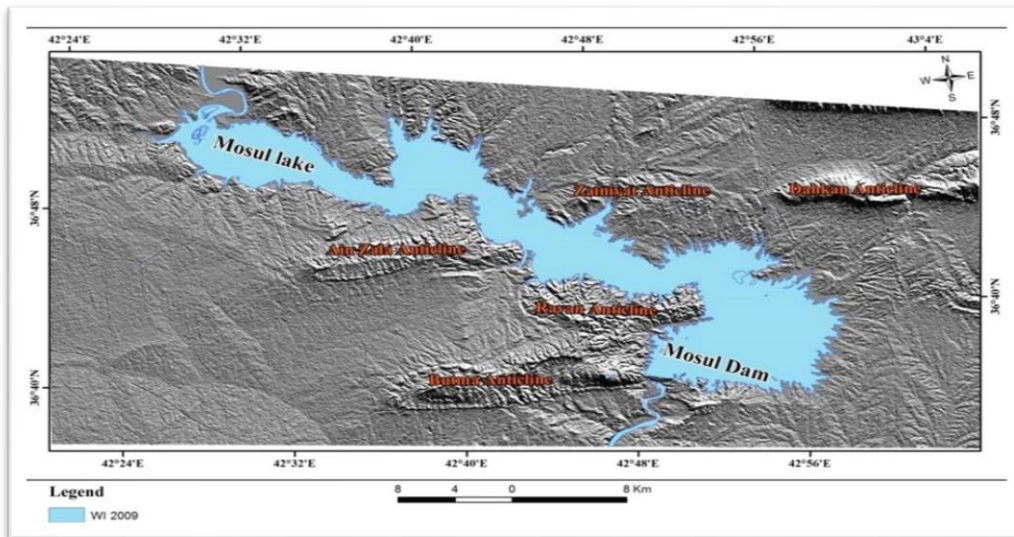

Figure 11- NDWI in 2000

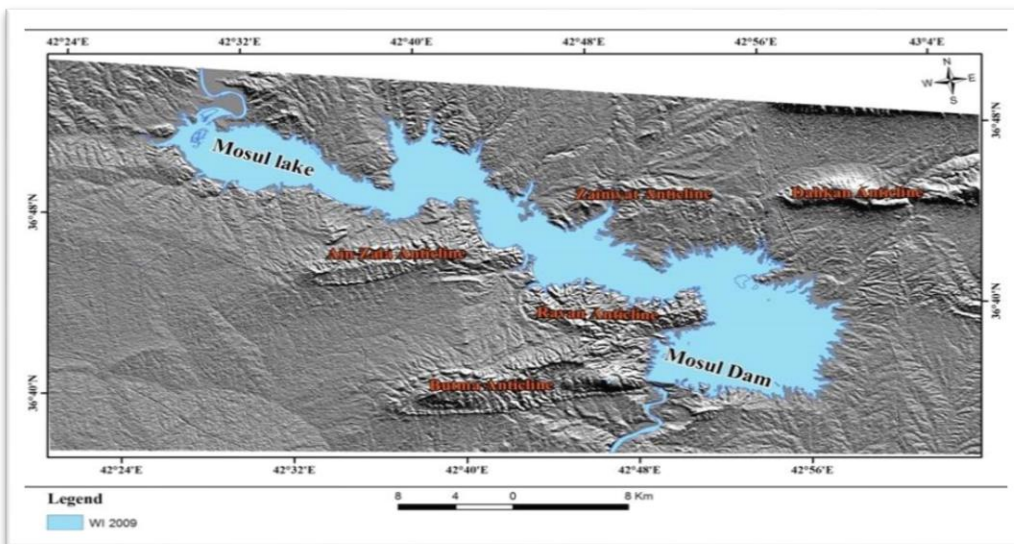

Figure 12-NDWI in 2009

**Water Index (WI) Change Detection**

Satellite image of MSS-1990 shows the surface area of water about 263.99 km<sup>2</sup> (29%) from the total area of the water area increased to about 339.80 km<sup>2</sup> (43%) from the total water area in satellite image of TM-2000 due to development of the dam and of Mosul Lake then decreased to be about 261.8 km<sup>2</sup> (28%) from the total water area in satellite image of TM-2009 due to retraction the water level in Mosul Lake and this attributed to climate conditions such as scarcity rates of rainfall. as in Table-3 and Figure-13 shows change in water, Figures-14 shows water distribution.

During the period 1990-2000, there is a noticeable positive change in surface area of the water body as shown in the middle part of the study area represented by Mosul Lake (135.8 km<sup>2</sup>). In the period 2000-2009, there is a negative change in surface area of water body (-138 km<sup>2</sup>)

**Table 3**-Surface area of water

<i>Water Index (WI)</i>	<i>Surface Area in km<sup>2</sup></i>					
	1990	p. %	2000	p. %	2009	p. %
	263.99	29	399.8	43	261.8	28



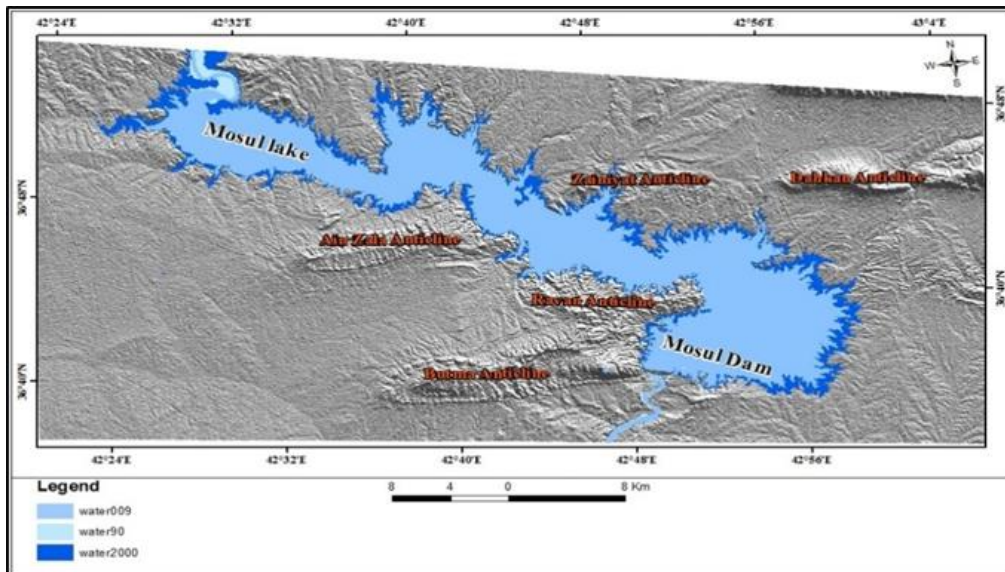

Figure 13-Change in Water Index

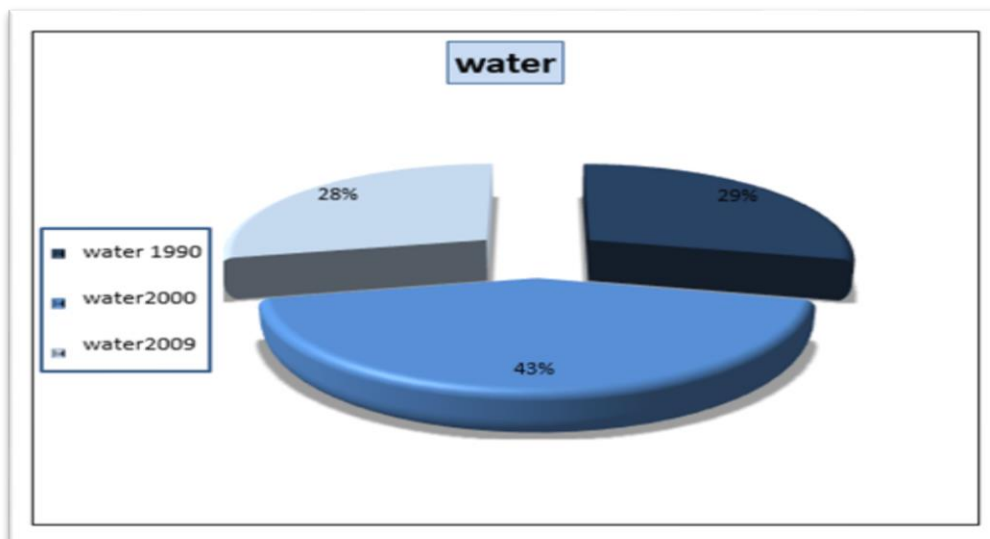

Figure 14-Diagram shows water distribution

**Barren Land Index (BLI)**

Barren Land Index (BLI) linear combination of measurements can be obtained in the spectral domains of IR bands and Near Infrared (NIR). It can be used to evaluate bare soil and desertification processes. In addition to, the glowing soil has shown to reduce values in water areas such as WI and vegetation indices such as NDVI. Barren Land Index (BLI) is well suited to arid and semi-arid areas where dominant vegetation types such as shrubs and other small vegetation is often photo synthetically inactive. A decrease in brightness can be due either to the wetting of the soil surface, soil roughness, or to degraded soil [20]. The equation (3) used for this index has been created by the researcher after so many attempts, which uses the MSS and TM images as follows:

$$BLI = (IR - NIR) / (IR + NIR) \dots (3)$$

Figures-(15,16 and (17) show the BLI images for the years 1990, 2000 and 2009 respectively.

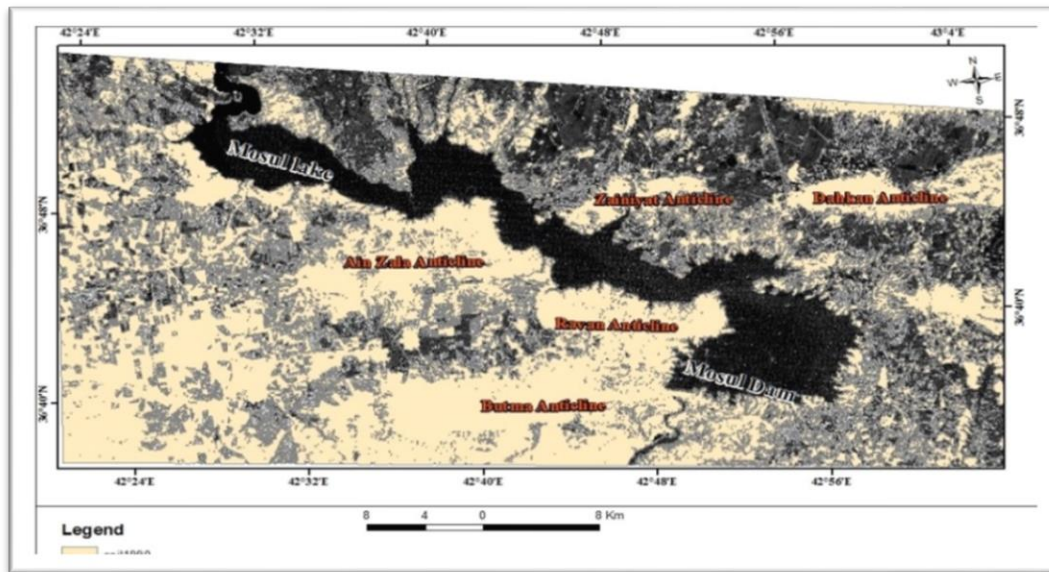

Figure 15-BLI in 1990

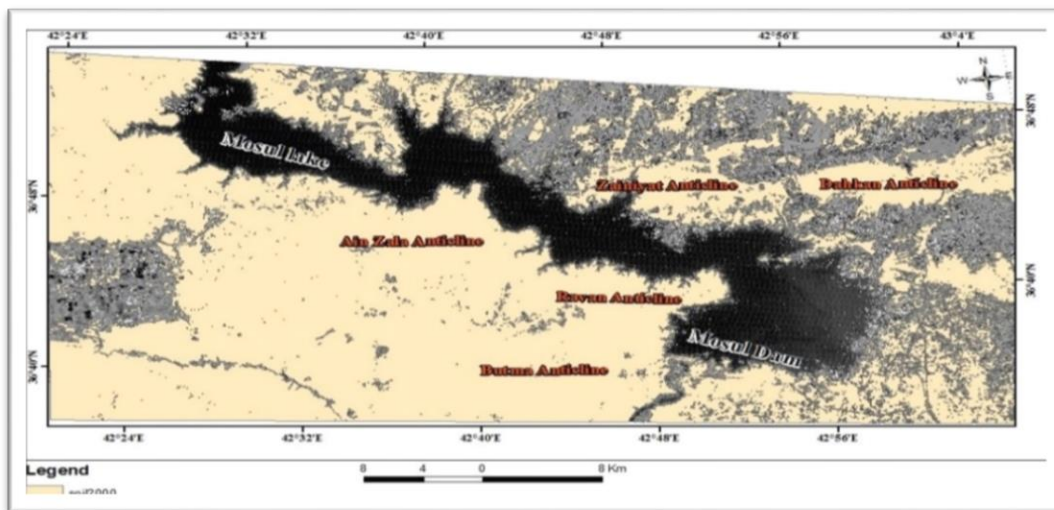

Figure 16-BLI in 2000

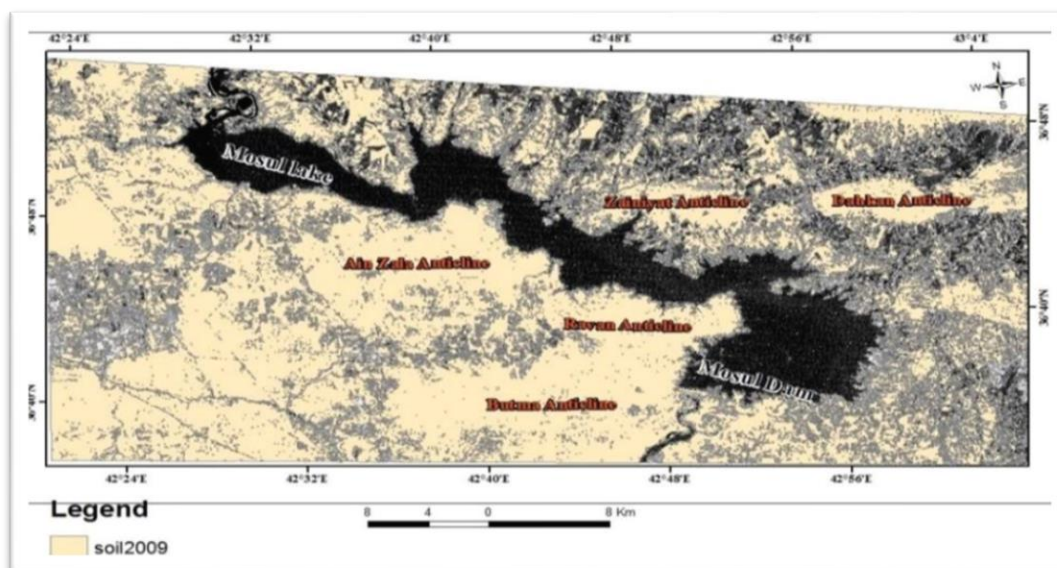

Figure 17-BLI in 2009



**Barren Land Index (BLI)**

**Change Detection**

Categories of Barren Land are: Dry Salt Flats, Beaches, Sandy Areas other than Beaches; Bare Exposed Rock; Strip Mines, Quarries, and Gravel Pits; Mixed Barren Land, besides river wash and mud flats.

In the study area barren Land is represented by bare soil, Salt flats, Mixed Barren Land, Exposed Rock, Sandy Areas. As in Tables- (4, 5), Figures-(18, 19, 20, 21) represent percentage of BLI.

The detail descriptions of these classes are given below:

**Bare Soil and Salt Flats Classes**

■ **Bare soil class**

The bare soil class covers a lot of area distributed over different sections in the study area. The results of image processing show change in the area of this class. In general, the area of bare soil is increased from 1990 to 2000 then decreased in 2009.

**Exposed Rocks and Sandy Areas Classes**

■ **Exposed Rocks class**

The Exposed Rock category includes areas of bedrock exposure, scarps, talus, slides, and other accumulations of rocks represented by sedimentary rocks that are exposed in the study area, which belong to different geological formations. It increased from 1990-2000 and increased from 2000-2009 due to retraction the water level in Mosul Lake because of the climate conditions such as scarcity rates of rainfall.

**Table 4-BLI Thresholding**

<i>Land use - Land cover (BLI)</i>	<i>Thresholding</i>		
	<b>1990</b>	<b>2000</b>	<b>2009</b>
Bare soil	0.283- 0.920	0.237-0.259	0.210-0.258
Mixed barren land	0.122- 0.217	0.259-0.293	0.258-0.279
Exposed Rocks	0.217- 0.283	0.293-0.555	0.279-0.671

**Table 5-Distributions BLI of area Changes**

<i>Land use - Land cover (BLI)</i>	<i>Surface Area in km<sup>2</sup></i>
1990	765.766
2000	1287.049
2009	1481.571

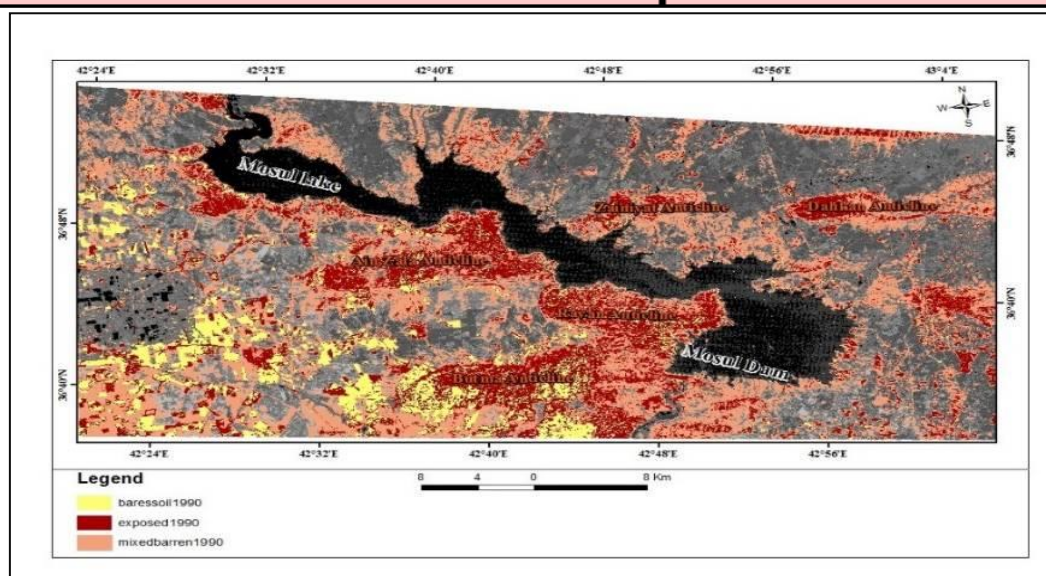

**Figure 18-BLI -1990**

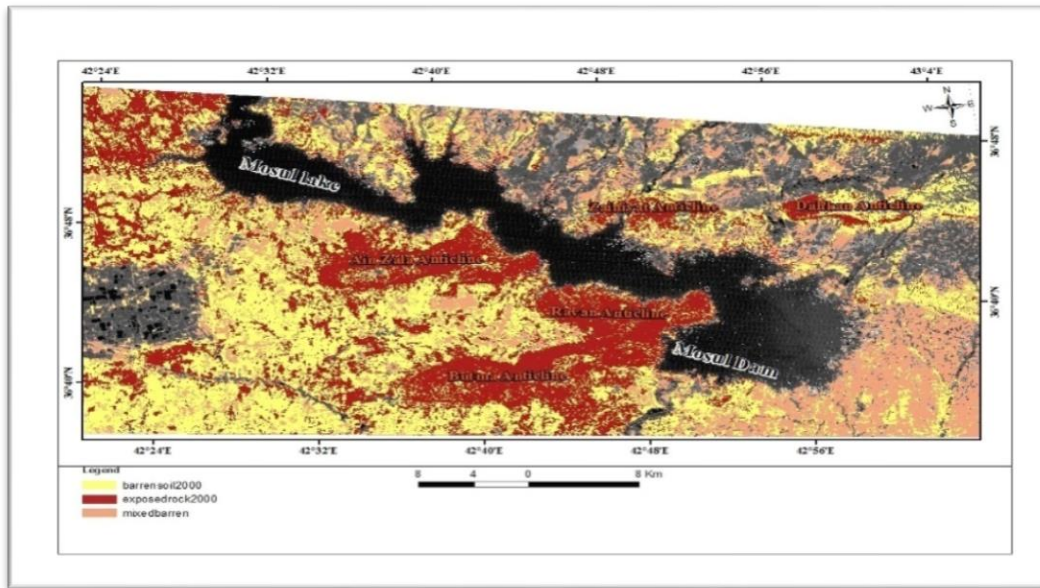

Figure 19-BLI -2000

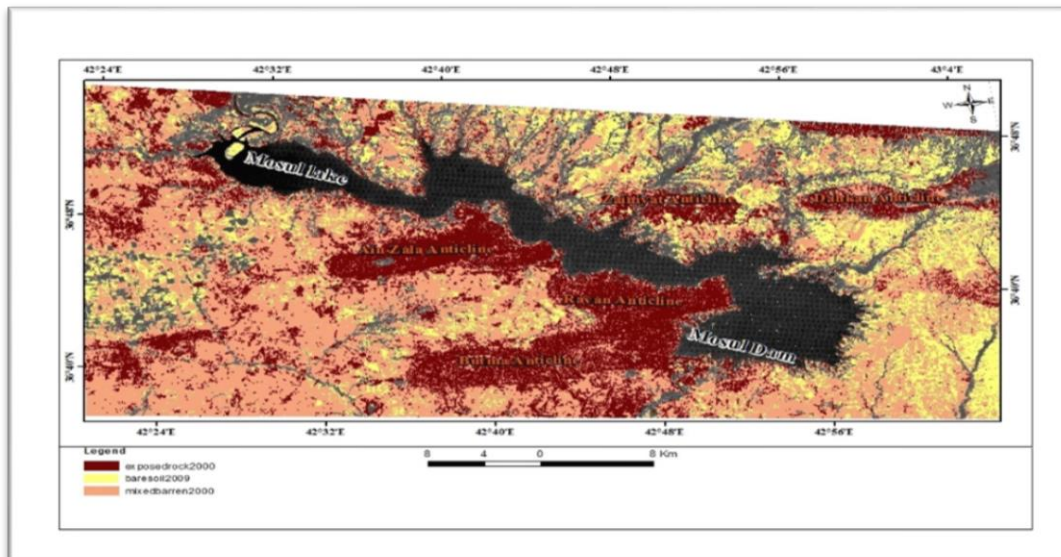

Figure 20-BLI -2009

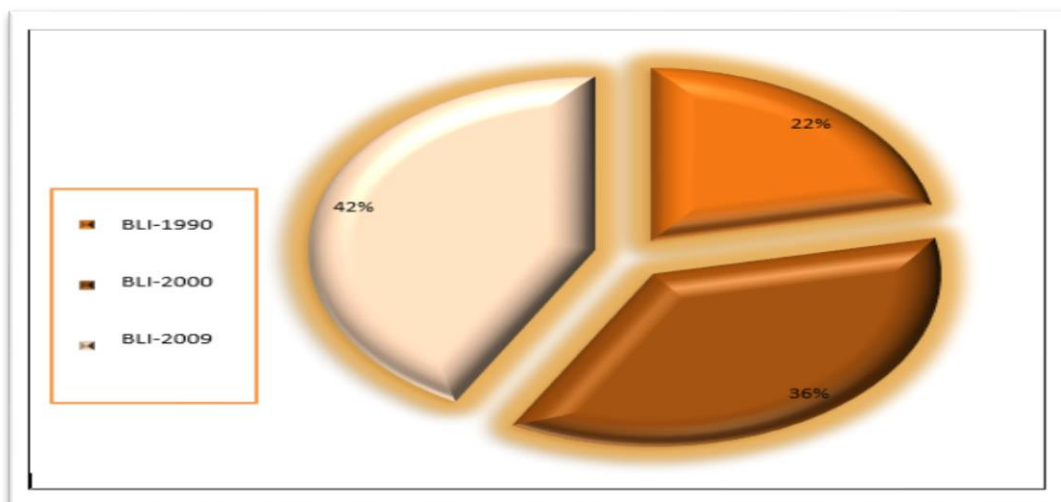

Figure 21-Percentage of BLI



### The Results of LULC Rate and Dynamic Change

The results of Land Use -Land Cover (LULC) rate and dynamic change for two periods are illustrated in Tables-(6, 7). For the period 1990- 2000 Table -6 shows that the rate of change of NDVI is decreased 590km<sup>2</sup> and the rate of change of WI is increased 135km<sup>2</sup> while the rate of change of BLI is decreased 521km<sup>2</sup>; therefore the area is considered affected by process represent repairing and reformation the land in the study area. In the period 2000-2009, Table -7 shows that the rate of change of NDVI is decreased 56 km<sup>2</sup> and the rate of change of WI is increased 138 km<sup>2</sup> while the rate of change of BLI is increased 194km<sup>2</sup>; therefore the area is considered affected by the process represent land degradation in the study area. Figure-22 illustrates the change in NDVI, WI, BLI, which took place during the period over the past 19 years. It outlines the situation, and gives some predictions of the changes in the study area which demonstrates negative change for the period 1990-2000-2009 due to the decrease in the area of agricultural land, and positive change for water body and barren land due to increase in the area.

**Table 6**-Rating values of LULC parameters for period1990-2000

Index	Area in km <sup>2</sup>		Rate of change in km <sup>2</sup> from 1976-1992
	1990	2000	
NDVI	866	208.8	-590
WI	263.9	399.8	+135
BLI	765.7	1287	+521

**Table 7**-Rating values of LULC parameters for period1990-2000

Index	Area in km <sup>2</sup>		Rate of change in km <sup>2</sup> from 1976-1992
	2000	2009	
NDVI	208.8	152.3	-56
WI	399.8	261.8	+138
BLI	1287	1481.5	+194

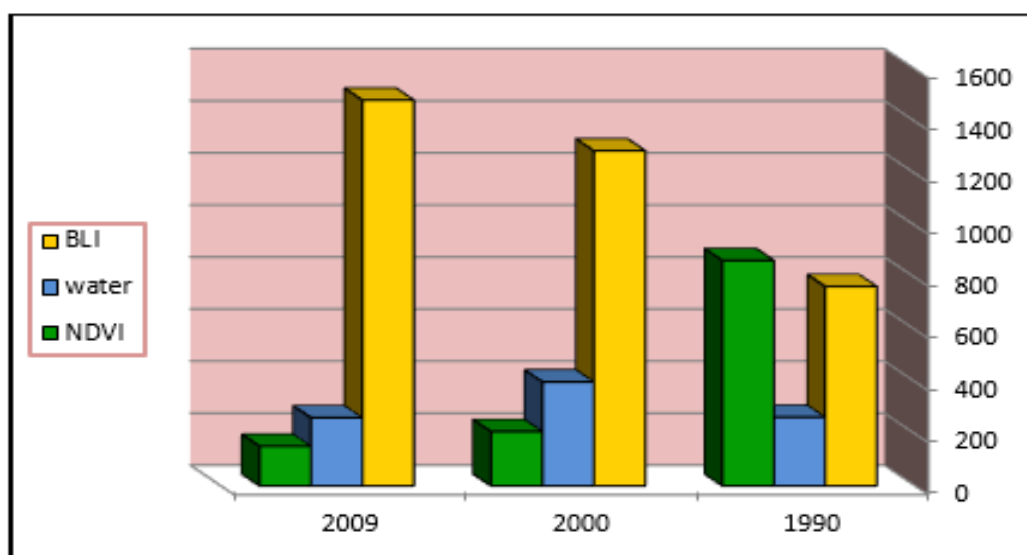

**Figure 22**-The change in indexes for three dates in the study area

Depending on the visual interpretation of the change maps for the period 1990-2000 and 2000 -2009 and statistical results. It can be inferred that the study area underwent significant environmental changes during the last 19 years. The most affected areas by human activities and natural factors occur in the central, south and northwest part of the study area, which has been severely affected by change in agricultural land and water body. The pattern of change evidently resulted from human

interferences and its negative effects on natural resources. These pressures are related to worse use of lands, which leads to degeneration of many arable lands in the study area. From the above, it is concluded that the relationships between human activities and natural factors (climate, desertification, transportation, weathering, erosion and precipitation) are the determinant factors for dynamics of LULC in the study area.

### Conclusions

1. The distributions of NDVI for the period 1990-2000-2009 showed negative pattern of (high vegetation density and moderate vegetation density) and positive pattern of (low vegetation density).
2. Application of NDWI during the period 1990-2000-2009, showed a positive change in surface area of the water body of the study area represented by Mosul Lake.
3. The changes of LULC in bare soil classes were positive during the period 1990-2000, and negative during the period 2000-2009, while the changes of LULC for mixed barren land class were negative of the period 1990-2000 and positive of the period 2000-2009, and the changes of LULC for exposed rocks classes were negative of the period 1990-2000 and negative of the period 2000-2009.
4. A portion of the blunders might be incompletely credited to the poorer nature of the TM information.
5. A few factors, for example, determination of reasonable change identification approach, appropriate band and ideal limit, may influence the achievement and exactness of the classification.
6. The effects of human activities are immediate and often radical, while the natural effects take a relatively longer period of time.
7. The change of LULC during the period 1990-2000-2009 was negatively represented by decreasing the area of vegetation and increasing of water body, and this evidence of the study area tends to desertification.

### References

1. Donia, N. S. and Farag, H. **2012**. Monitoring Burullus lake Using Remote Sensing Techniques. Sixteenth International Water Technology Conference, IWTC 16 2012, Istanbul, Turkey.
2. Arya, A.S., Ajai, P.S., Dhinwa, V.S and R.S Hooda, R.S. **2011**. Desert ecosystems: mapping, monitoring & assessment using satellite remote sensing, *International Archives of the Photogrammetry, Remote Sensing and Spatial Information Sciences*, Volume XXXVIII-8/W20,
3. Elshookie, M. M., N.Younis and M. J. AlKhafajy. **2013**. Performance, variance components and heritability of oats cultivars under irrigation intervals. *The Iraqi Journal of Agricultural Sciences* ,**44**(1): 1-15.
4. Escadafal, R. and Bacha, S. **1996**. Strategy for the Dynamic Study of Desertification. Proceedings of the ISSS *International Symposium Ouagadougou*, Burkino Faso, 6-10 February 1995, 19-34..
5. Glantz, M. H., and Orlovsky, N.S. **1983**. Desertification: A review of the concept. *Desertification Control Bulletin* **9**: 15-22.
6. Jensen, J. R. **1996**. *Introductory digital image processing: A remote sensing perspective*. 2<sup>nd</sup> edition, New Jersey, U.S.A: Prentice Hall, 257-278.
7. Quintanilla, E.G. **1981**. Regional aspects of desertification in Peru. In *Combating Desertification through Integrated development*, UNEP/UNEP/COM *International Scientific Symposium*, Abstract of Papers, Tashkent, USSR, PP.114-115
8. Zonn,I.S.(ed.) **1981**.USSR/UNEP Projects to Combat Desertification. Moscow, *Center of International Projects* GKNT, 33.
9. Anderson, J. R., E. E., Hardy; J. T., Roach and R. E., Witmer, **1976**. Land-use and Land-cover Classification System for Use with Remote Sensing Data, USGS, *geological survey professional paper 964* United States Government printing office, Washington,PP. 1-28,(Report),
10. Adia, S. O., Rbiu, A. B. **2010**. Change Detection of Vegetation Cover, Using Multi-temporal Remote Sensing Data and GIS Techniques. *International Symposium: Benefiting From Earth Observation*, 4 - 6 October, Kathamandu, Nepal.
11. Nogi, A., Sun, W. and Takagi, M. **1993**. An alternative correction of atmospheric effects for NDVI estimation. *International Geosciences and Remote Sensing*, **3**: 1137- 1139.
12. Tarpley, J. D., Schnieder, S. R. and Money, R. L. **1984**. Global vegetation indices from NOAA-7 meteorological satellite. *Journal of Climate and Applied Meteorology*, **23**: 4491-4503



13. Hesse, P .R. **1971**. A text Book of Soil Chemical Analysis. John Murray. LTD. London, British.
14. Harrison A.R. and Garg P. **1991**. Multispectral classification for vegetation monitoring in semi-arid landscape susceptible to soil erosion and desertification. Gordon and Breach Science Publishers. Amsterdam.
15. Faleh. H. Mahmood and A. N. Ali. **2014**. Using remote sensing techniques to assess land use/land cover change in Laylan Sub-District, Kirkuk province, Iraq. *Iraqi Journal of Science*. **55** (2B): 845-851.
16. Najeeb; A. A. Z. and Faleh. H. Mahmood. **2012**. Effect of land degradation degree on the land cover type using GIS technology in the west of Baghdad/Iraq, *Iraqi Journal of Science*. **53**(2): 444-453.
17. Zahraa, R. A. and Ahmad S. M. **2016**. The study of temporal changes on land cover/land use prevailing in Baghdad governorate using RS & GIS. *The Iraqi Journal of Agricultural Sciences –* **47**(3): 846-855.
18. Normalized Difference Water Index (NDWI), **2011**. *Product Fact Sheet: NDWI – Europe* Version-1.
19. Wheib, K. A. **2012**. Spectral reflectance properties of soil surface and land covers of AL-Salman depression in southern Iraq .*The Iraqi Journal of Agricultural Sciences –*43(4),(Special Issue): 129-140.
20. Sabins, F. F., Jr. **1987**. *Remote Sensing Principles and Interpretation*. 2<sup>nd</sup> Ed. New York: W. H. Freeman & Co.