



ISSN: 0067-2904

Fabrication of Vertical Axis Wind Turbine (VAWT) for a Water Pump at Low Speed Wind in Tikrit Region

Yaseen H. Mahmood^{1*}, Muataz A. Majeed², Ahmed Abdul Razzaq Niema³

¹ Department of Physics, College of Sciences, University of Tikrit, Tikrit, Iraq

² Ministry of Education, Baghdad, Iraq

³ Department of Remote sensing and Geographic information systems, College of Science, Baghdad University, Baghdad, Iraq.

Received: 8/4/2021

Accepted: 6/6/2021

Published: 30/4/2022

Abstract

We have designed, fabricated and studied the vertical axis wind turbine and its characterization. The system has been locally designed to pump water. It is considered as a one of the best options for low speed wind. The turbine has eight blades, each blade is 1.8m in length, and the area dimension of the turbine 3.6 m². We investigated the best characterization of the system at low wind speed. Power turbine depends on the wind speed. It was 280 Watt at 6m/s and 160 watt at 5m/s, and the power after the turbine decreasing to factor 1/3. The system torque was 20 N.m, Power coefficient cap 0.29, Tip speed ratio 0.46. It is suitable to be used in Iraq region, and low cost for get the water, It is important to reduce desertification and increase investment.

Keywords: Renewable Energy, Wind Turbine, Wind Pumps design, vertical axis wind turbine, blade design, water pump

تصنيع توربين الرياح ذو المحور الرأسي كمضخة مياه عند سرعة الرياح الواطئة في مدينة تكريت

ياسين حميد محمود^{1*}, معتز عيال مجيد², احمد عبدالرزاق نعمة³

¹ قسم الفيزياء, كلية العلوم, جامعة تكريت, صلاح الدين, العراق

² وزارة التربية, بغداد, العراق

³ قسم الاستشعار عن بعد ونظم المعلومات الجغرافية, كلية العلوم, جامعة بغداد, بغداد, العراق

الخلاصة

تم تصميم وتصنيع ودراسة توربين الرياح ذو المحور الرأسي وتوصيف خصائصه. وقد صممت المنظومة من مواد محليا لغرض ضخ المياه، حيث تعتبر المنظومة العمودية واحدا من أفضل الخيارات عند سرعة الرياح المنخفضة. وقد استخدمنا التوربين ذو ثمانية شفرات، وكانت مساحة التوربين (3.6 م²) كما وجد ان أفضل خصائصه عند السرعة الواطئة حيث كانت القدرة للتوربين 200 واط، والعزم 20 N.m، معامل القدرة 0.29، ونسبة سرعة الطرف 0.46، وهو مناسب في المناطق العراقية وذات كلفة منخفضة في الحصول على الماء، وهدف العمل الحد من التصحر وزيادة الاستثمار.

*Email: D.yaseen.ph.sc@tu.edu.iq

1. Introduction

In the last 50 years, interest in renewable energy has increased considerably because of the increasing global need for energy and because of pollution increase. The scarcity of water used for human and agricultural use has led researchers to seek new, clean, environmentally-friendly sources of energy, so researchers have developed systems or parts of systems to make use of solar energy, wind energy, water energy, etc. [1-3]. By using a wind tunnel many practical experiences for (VAWT) wind turbine to find the blade shape effect, show the increase in torque with the low speed with greater angle [4]. The performance of the small vertical axis wind system in an environment with a disturbance density greater than 30%, the effect of the vertical angle of the turbine, the horizontal speed of the wind, and the intensity of the turbulence on the output of electrical power. the results were that more than 90 percent of the energy is generated when the vertical angle is less than or equal to 4 [5]. The height and diameter of the wind system is an important factor, in the performance of the rotors. Therefore the most appropriate choice when designing wind turbine, and the ratio between height and rotor diameter has been analysed [6]. The impact of solidity and number of blades on the aerodynamic analysis of the vertical wind system Darius, The results show that the turbine optimal tip speed ratio (λ_{opt}) is invariant to a newly introduced parameter [7]. Assemble a useful wind turbine and to analyze the presentation of two sorts of plan for wind turbine under various paces and practices of the wind. A three-cutting edge flat hub wind turbine (HAWT) and a Darrieus-type vertical hub wind turbine (VAWT) have been planned with CATIA programming and built utilizing a 3D-printing strategy [8]. A 2.14m wind-powered pump model with a rotor giving an all-out surface region of 3.7m² and the solidity of 0.654 with a normal wind speed of 2.5 m/s at 16m over the ground level. A (HAWT) windmill with 3 rotor blade better rotor offset with a most extreme pump head of 0.3m to beat different obstructions to movement. The wind turbine works by transferring the wind part of its kinetic energy to the turbine, which turns into mechanical energy where the kinetic energy depends on its weight and speed square. Part of the wind power can also be diverted through the wind turbine by pushing the wind energy of the turbine blades to rotate the axle and depends on the turbine area as well as the geometric shape of the blades so that less wind power can be used. The turbine The Execution trial of the created wind pump uncovered an adequate release stream rate inside the scope of 3.4 to 6.44L/min for water system reason [9]. Dynamic Modeling is used to estimate the wind velocity with an error of 2%. The wind speed is estimated to the commonplace rather than measuring, from the rotating speed and generator power and the turbine's aerodynamics including shadow tower, without having to measure the speed at any height of the blade position [10]. A wind turbine-water pump framework was introduced and assessed for its presentation and productivity. Wind turbines vary according to the spin axis, some are horizontal turbine(HAWT) and are most prevalent. The other is perpendicular to the spin axis, which is known as Darrieus and Savonius turbine (VAWT), where it depends on how the blades are fixed to the spin axis, this type of turbine exploits wind power from all directions. The outcome has demonstrated a direct connection between water release capacity and wind speeds. Because of the kind of turbine and low wind speed in this area, the framework effectiveness ended up being negligible, yet it was down to earth in light of the fact that the Wind control was free. A straightforward cost examination from the overview information additionally has demonstrated that utilizing a wind turbine in this locale will be beneficial when it tends to be worked for around two decades [11]. A windmill for pump water. The vertical multi-edge wind turbines and single-acting responding. The pump forces two main impetuses to lift and delays the edges of the turbine. At the point when these powers follow up on the edge, it turns and this turning sharp edge changes over the rotating movement of the windmill to responding movement of pump. This is the means by which the water is released [12].

The of this study is to design and fabricate a vertical axis wind turbine system for the exploitation of wind energy from all directions. The system was made of local and cheap materials. The turbine has a central spin axis and is mounted with metal arms to install the eight blades with length 1.8 m . The geometry was chosen as a parabola to exploit the largest volume of air at the lowest wind speed, as increasing the number of blades and increasing blade fatigue played a major role in making the system operate at low speed and efficiently to exploit wind energy.

2.Theoretical part

2.1 wind turbine

The function of wind turbines is extracting energy from the wind and converting this kinetic energy into mechanical energy for use in generating electricity or raising water or other applications. The wind energy is proportional to the third power of the wind speed as in Equations (1,2) [13].

$$P_{total} = 0.5 \rho A v^3 \quad (1)$$

Where: P_{total} is the wind power; ρ is the air density in (Kg/m^3); A is the area of turbine and v is the wind speed [14].

$$P_{actual} = C_p 0.5 \rho A v^3 \quad (2)$$

Where: P_{actual} is the actual wind power; C_p is the power coefficient; D is the diameter of turbine (m) [15].

Therefore, the power coefficient factor can be found from the ratio of the power obtained from the wind to the total power (Equation (3)) . The area of vertical axis wind turbine can be found by Equation (4).

$$C_p = \frac{P_{actual}}{P_{total}} \quad (3)$$

$$A = \frac{\pi D^2}{4} \quad (4)$$

The tip speed (λ) can be found from Equation (5,6)[15]

$$\lambda = \frac{\text{blade tip speed}}{\text{Undisturbed wind speed}} \quad (5)$$

$$\lambda = \frac{\omega R}{v_0} \quad (6)$$

Where: R is rotational speed of the turbine, v_0 is the undisturbed wind speed m/s ,
 ω is the angular velocity

The torque of turbine (T) is given by Equation (7)

$$T = \omega \times R \quad (7)$$

The undisturbed wind speed (m/s) found from Equation (8) [16]

$$v_0 = \frac{\omega R}{\lambda} = \frac{2\pi NR}{\lambda} \quad (8)$$

$$\omega = 2\pi N \quad (9)$$

Where: N is the number of blade [16]

2.2 Pump Power

To calculate the energy needed by the pump water, it is necessary to know the height from which the water will be extracted, and how much water will be pumped into it. Dynamic pump height (H_d) should be calculated equation (10):

$$H_d = H_W + H_S \quad (10)$$

Where: H_W is the Water depth from Earth's surface H_S is the height of the water above the surface of the earth

The value of the theoretical power needed to pump P_W water can be found from the Equation (11)[17,18]. Where : P_W The theoretical capacity to pump water

$$P_W = \rho g H_d Q_W \quad (11)$$

3. Experimental work

Wind turbine was locally fabricated for water pump. It is constituted of many parts

3.1 Base

The turbine base was designed and manufactured from affordable, cheap and highly efficient materials. It was designed to withstand the stress and vibration of the turbine. It is of pyramid-shaped, (100 cm) height, made of wrought iron. The base is squared-shaped with a one side length of (60 cm). It is well-secured to the ground to resist strong winds. The turbine is fixed above the base. Figure 1, represents Scheme for turbine base.

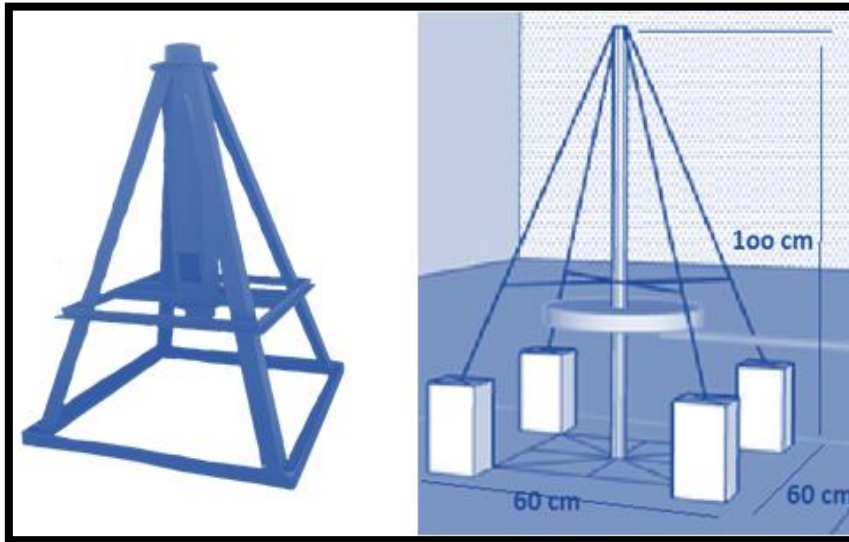

Figure 1-The base of the system .

3.2 Blade

The blades are made of aluminum as a strong, non-impact, lightweight material that does not weigh on the system. They are parabolic in shape with dimensions (30cm width, 180cm height). As the wind hits the blades, wind energy is converted to kinetic energy. These blades are attached to an axle by means of the blade load arms with two screws. They are easy to fit so that they can be changed easily, as shown in Figure 2.

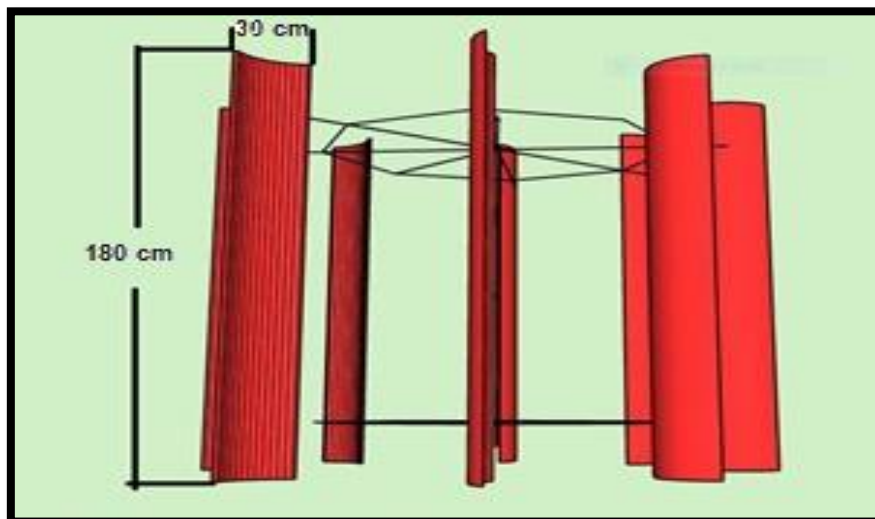

Figure 2- The turbine and the blades.

3.3 Turbine

The eight blades are mounted on two metal octagonal shafts. The rotor shaft is fixed in the centre by two ball-bearing to carry the structure. The turbine dimensions are (1.8 m * 2.5m) (Figure 2).

3.3.1 Hub

A light weight durable iron hollow column has been used to withstand the stress and tension of the axle. It is with dimensions of 0.03cm thick ,3.5cm diameter, 250 cm long . It is responsible for delivering the movement of the blades, which are attached to the axle by means of the blade load arms, resulting from the wind energy. The axle is linked to the base by a ball-bearing, as shown in Figure 3.

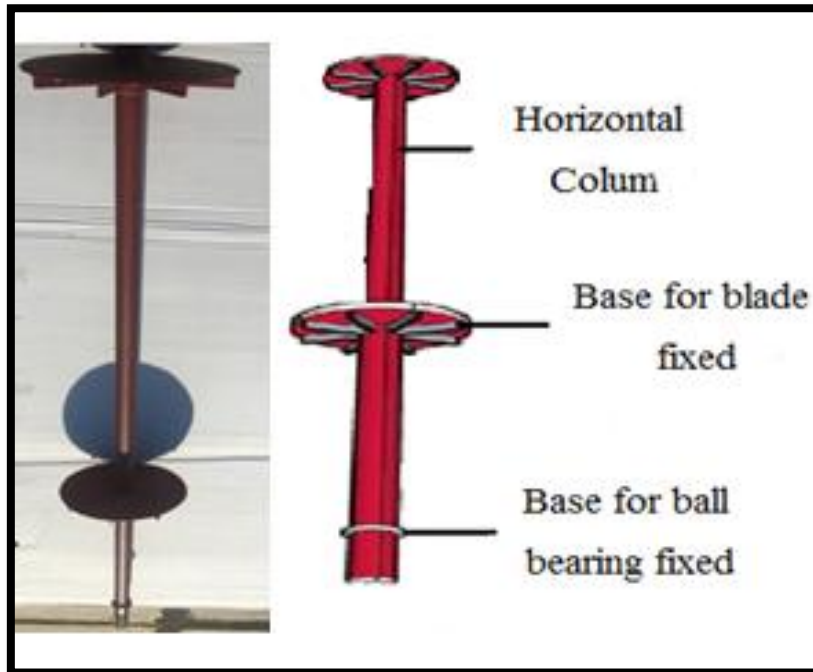

Figure 3- The Hub.

3.3.2 The Crow -bar for movement

To facilitate movement, a rigid rod (thickness 1 cm length , 150 cm) was used . Connected and installed on the one hand with the hard disk and on the other hand with a triangle-shaped crowbar where it converts the rotational motion into a horizontal linear motion that transfers the motion from the disk to the crowbar via an arm. This crowbar converts the horizontal linear motion to a vertical motion as in the form Figure 4.

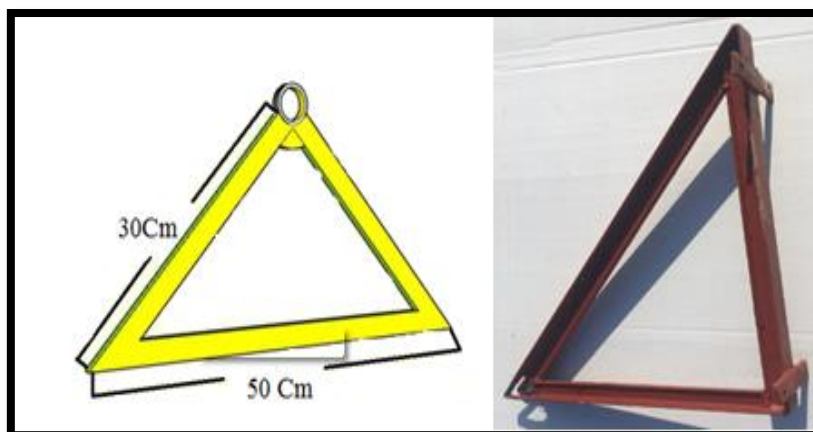

Figure 4- The Crow -bar .

3.4 Fly well

A hard disk with dimensions (5 cm thick, 33 cm wide, 24 kg weight) has been used to help the stability of the turbine. It absorbs and stores energy in the form of rotational torque. With this disc, the rotational motion of the axis is converted into horizontal linear motion by a small lever attached under the two colons as shown in Figure 5.

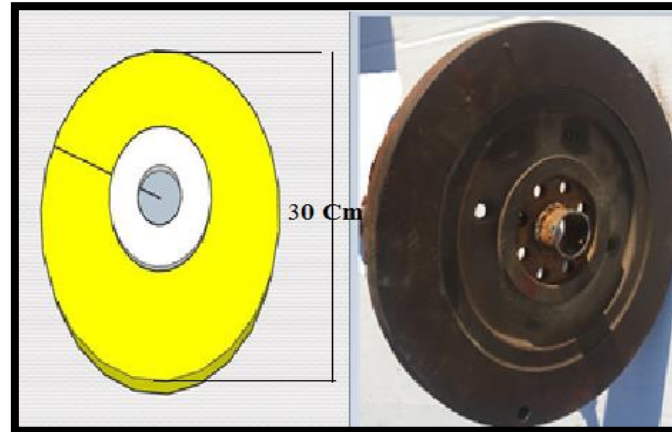

Figure 5- Show fly well.

3.5 Pumps

A pump of available, inexpensive and highly efficient materials was manufactured using a 5 cm diameter hollow plastic tube, 100 cm long with a valve mounted from the bottom that allows water to enter and is not allowed out, installed with a 1 cm diameter iron lip and length. (150 cm) Attached to the piston valve (sliding head), moving upwards, the water enters the cylinder and pushes the air out, as in Figure 6.

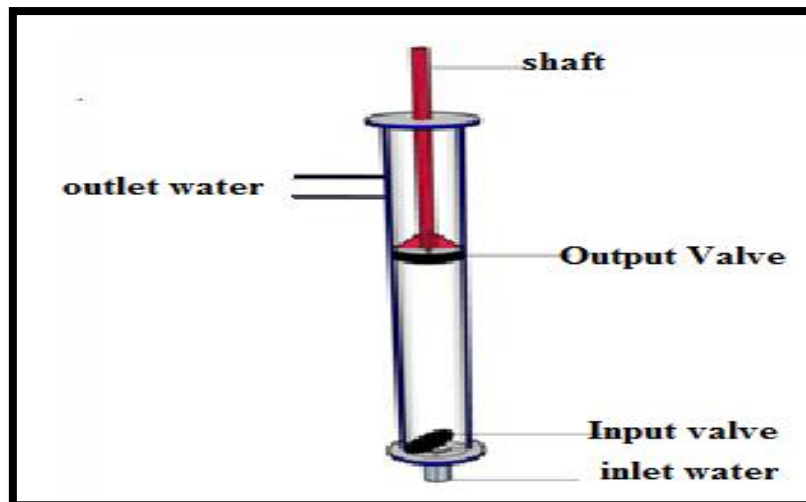

Figure 6- Show water pump assemble

3.6 Working of the system

When the system blades are exposed to wind in any direction, wind speed kinetic energy will become rotational energy that moves the axle; a hard disk mounted at the bottom of the axle absorbs energy and converts it into rotational torque; as the hard drive mounted the movement lever attached to it, an axis that converts the movement of the turn into a horizontal linear movement and then into a triangular lever that transforms the movement from a horizontal linear movement to a linear vertical movement in which a lever connected to the pump is attached to the other side and which draws and compresses the plunger to lift water from wells and streams and as shown in Figure 7.

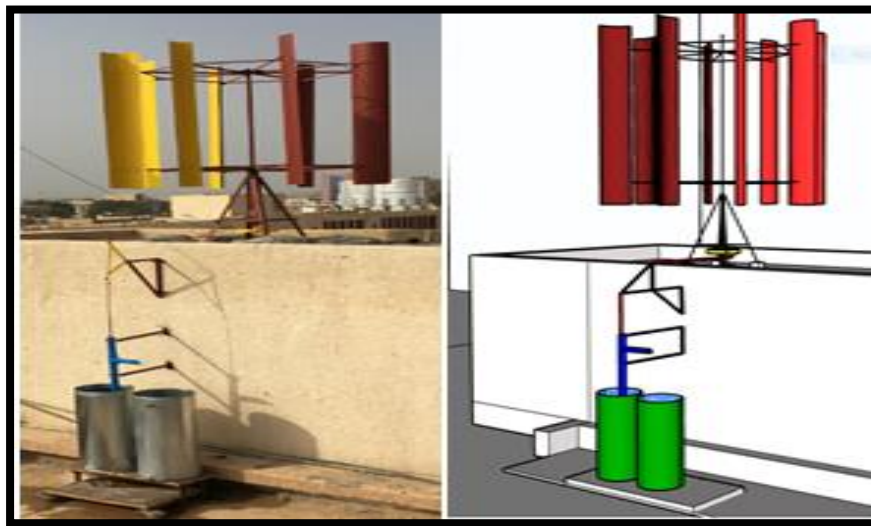

Figure 7-Show the wind turbine water pump.

4. Result and discussion:

Wind speed is an important factor in the study of wind energy. The experiments were conducted in (Salah - ALdin Tikrit, located at the longitude line (43.35) east, and the latitude line (34.27)North). The power changes with wind speed changes was studied and measured the direct (before) , and when wind speed pass through the turbine (after) It was found, as shown in Figure 8, that the power increases with increasing the wind velocity ,according to Equations (1 and 2) since the power depends on the third power of velocity the wind speed before turbine results in the power , as it passes through the turbine, taking into account the turbine area , and after interacting with the blades, it moves the turbine to take advantage of wind energy, so the power after turbine is reduced with the provision of kinetic and torque agreement with [19]. The power coefficient is calculated because it is an expression of the efficiency factor of the wind turbine. Also The power coefficient of the turbine is a function of the tip speed ratio, and depends on the diameter of the wind turbine, which was considered to be constant in the measurements. The efficiency value of the turbine is the power coefficient, which expresses the output power to input power of the turbine with constant wind turbine area . Time, in this case, has no affect but wind speed and energy have. The geometry of the blades was chosen as a parabola to exploit the largest volume of air at the lowest wind speed.

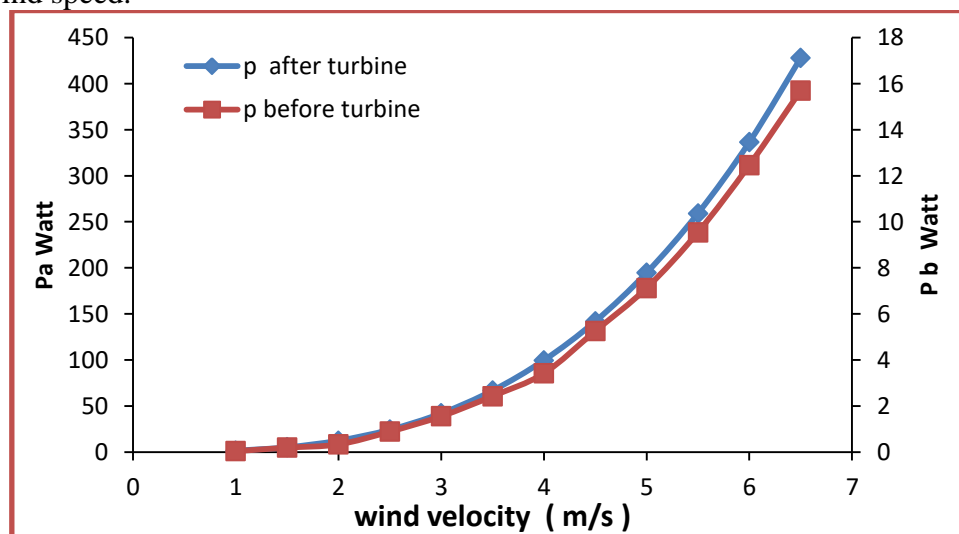

Figure 8- Relation between wind velocity after and before turbine with power

Additionally, the power coefficient C_p was studied as a function of tip speed ratio. From Equations (3 and 6) and as shown in Figure 9 for wind speed of (1 to 6) m/s, it was found that C_p increased as the tip speed ratio increased, reaching a maximum then again decreases gradually. This conduct is an agreement with that of Kishore et al. [20].

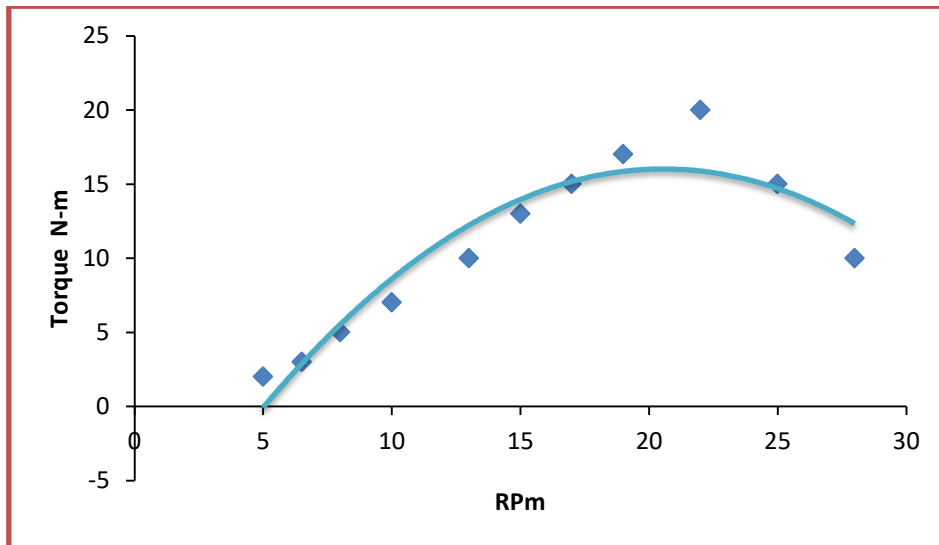

Figure 9-Power coefficient C_p versus tip speed ratio.

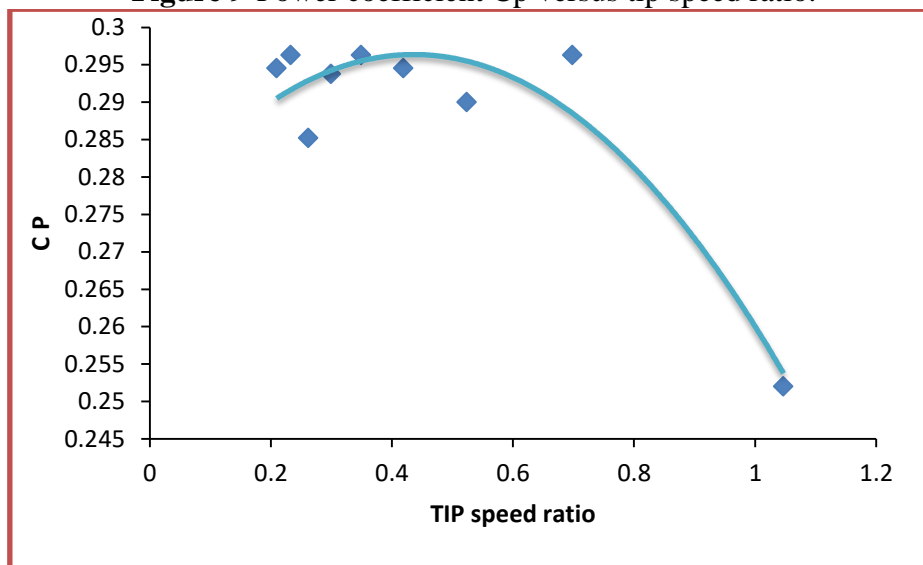

Figure 10-variation of the torque with number of cycle (Rpm).

The number of cycles of the turbine was calculated in practice, from Equations (7 and 8), to find the torque of the turbine axis. It was found that the turbine torque increased as the number of cycles increased, as shown in Figure 10. This resulted from an increase in turbine power [21] meaning that the eight-blade turbine provided enough torque to move the pump within a relatively low wind speed.

From the study of the aerodynamic effect of the speed and pressure of the wind effect on the eight-blade turbine using the Ansys Fluent program, (as shown in Figure 11), an increase in the effect was observed from the top and from the bottom of the high-velocity yellow colour. It was reduced by reversing the wind velocity from behind the turbine and less than the front dark colour, which would increase the pressure from above, making the turbine rotate well, even at low speed, and increase the effect with increased speed. This results agrees with that of Rogowski et al. [22].

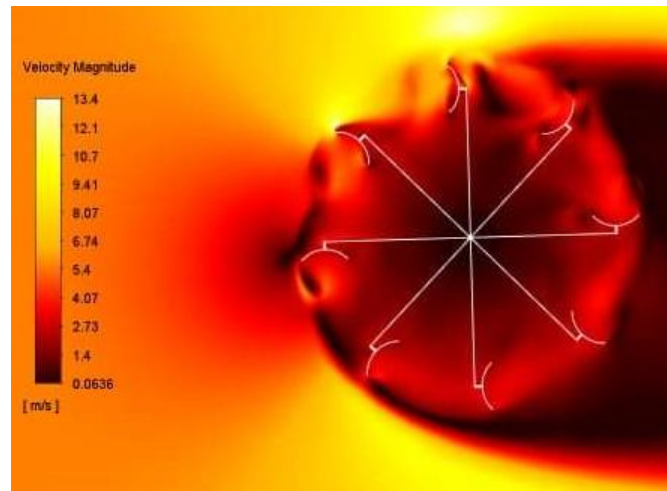

Figure 11-CFD analysis of 2D Velocity contour.

4.1 Measuring the flow rate with wind speed

Wind pump flow rate was calculated using the relationships (10 and 11); the experimental results of the pump were obtained at different wind speeds based on the system's capacity, Figure 12. It was observed that the flow rate of water increased with the increase of wind speed as the increase in wind speed led to an increase in the number of turbine cycles. The number of strokes in the water pump thus increases the amount of water received. This is in accordance with Patel[23] and Luna et al.[24].

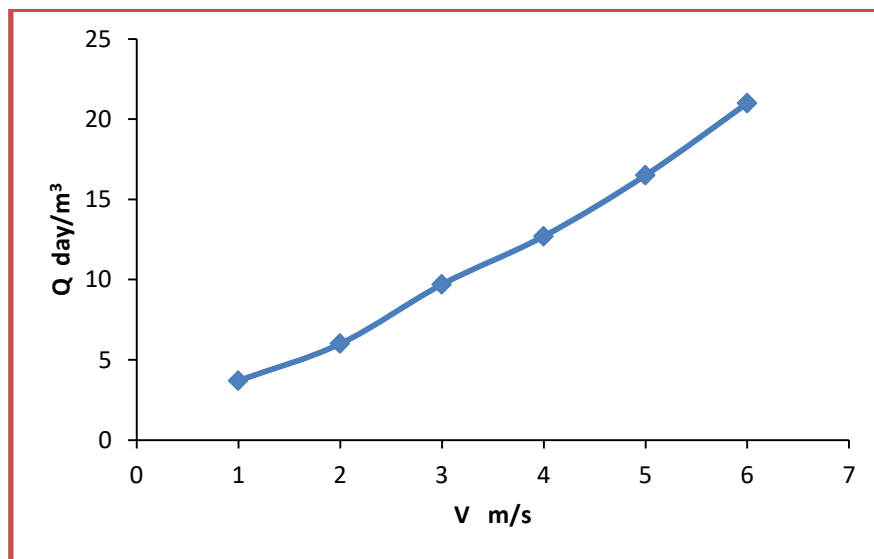

Figure 12-Relation between wind speed and water flow rate.

5. Conclusion:

Design and manufacture of a system for drawing and pumping water from wells or rivers using wind energy, in Salah-ALdin Iraq, was introduced. The selection of an eight-blade vertical turbine has helped well to obtain a proper spin speed and torque within the low wind speed. The pump was simple and cheap but effective in pumping water. The system was good and effective for the conditions of the region, which is characterized by abundant agricultural land, and is useful to provide water for agricultural land where providing electricity in remote agricultural areas is difficult. It is a promising start to provide water-raising systems for agricultural land and animals .

References

- [1] R. D Gandhi, D. Sharma, B. Kumbhare, and S. Choukade, "Design and Development of Windmill Operated Water Pump." *International Journal of Innovative Research in Science, Engineering and Technology*, vol. 5, no. 1, pp. 392-413, 2016.
- [2] H. kadhim khashan, "Design and Development of Wind Power Water Lifting Pump Mechanism." *International Journal of Science Technology & Engineering*, vol.2 no. 12, pp. 651-655, 2016.
- [3] N. Khattab, M. Badr, and E. Tawfik El Shenawy, "Feasibility of hybrid renewable energy water pumping system for a small farm in Egypt." *International Journal of Applied Engineering Research*, vol. 11, no. 11, pp. 7406-7414, 2016.
- [4] H. Dumitrescu, A. Dumitrache, C. Popescu, M. Popescu, F. Frunzulică, and A. Crăciunescu, "Wind Tunnel Experiments on Vertical-Axis Wind Turbines with Straight Blades." *Renewable Energy and Power Quality Journal*, vol.1, no.12, pp. 1001-1004, 2014, doi: 10.24084/repqj12.562.
- [5] K.-Y. Lee, S.-H. Tsao, C.-W. Tzeng, and H.-J. Lin, "Influence of the vertical wind and wind direction on the power output of a small vertical-axis wind turbine installed on the rooftop of a building." *Applied Energy*, vol. 209, pp. 383-391, 2018, doi: 10.1016/j.apenergy.2017.08.185.
- [6] Rabei and M. Guțu, "Analysis of the influence of the aspect ratio on the vertical axis wind rotor performance." *IOP Conference Series: Materials Science and Engineering*, vol. 564, p. 012076, 2019, doi: 10.1088/1757-899x/564/1/012076.
- [7] Rezaeiha, H. Montazeri, and B. Blocken, "Towards optimal aerodynamic design of vertical axis wind turbines: Impact of solidity and number of blades." *Energy*, vol. 165, pp. 1129-1148, 2018, doi: 10.1016/j.energy.2018.09.192.
- [8] M. Khudri Johari, M. Azim A Jalil, and M. Faizal Mohd Shariff, "Comparison of horizontal axis wind turbine (HAWT) and vertical axis wind turbine (VAWT)." *International Journal of Engineering & Technology*, vol. 7, no. 4, p. 74, 2018, doi: 10.14419/ijet.v7i4.13.21333.
- [9] M. Sasikumar, V. R. J. Vince, and V. Sridevi, "Pump Motor Control System using Wind Powered Impedance Bridge Inductor Capacitor Integral Converter." 2019 Fifth International Conference on Science Technology Engineering and Mathematics (ICONSTEM), 2019, doi: 10.1109/iconstem.2019.8918764.
- [10] A. G. Abo-Khalil, S. Alyami, K. Sayed, and A. Alhejji, "Dynamic Modeling of Wind Turbines Based on Estimated Wind Speed under Turbulent Conditions." *Energies*, vol. 12, no. 10, p. 1907, 2019, doi: 10.3390/en12101907.
- [11] C. Prabkeao and A. Tantrapiwat, "Study on wind energy potential for agricultural water pumping system in the middle part of Thailand." *MATEC Web of Conferences*, vol. 192, p. 03058, 2018, doi: 10.1051/mateconf/201819203058.
- [12] Lukiyanto, "A Couple of Savonius Wind Mill and Centrifugal Reaction Pump as a Wind Energy Water Pump System." *Applied Mechanics and Materials*, vol. 836, pp. 299-303, 2016, doi: 10.4028/www.scientific.net/amm.836.299.
- [13] C. Anderson, *Wind Turbines*. Cambridge University Press, 2020.
- [14] S. Bhattacharya, *Design of Foundations for Offshore Wind Turbines*. John Wiley & Sons, 2019.
- [15] D. Dolan and P. Lehn, "Simulation Model of Wind Turbine 3p Torque Oscillations due to Wind Shear and Tower Shadow." *IEEE Transactions on Energy Conversion*, vol. 21, no. 3, pp. 717-724, 2006, doi: 10.1109/tec.2006.874211.
- [16] S. Schmitz, *Aerodynamics of Wind Turbines*. John Wiley & Sons, 2020.
- [17] T. Aized, S. M. Sohail Rehman, S. Kamran, A. H. Kazim, and S. Ubaid ur Rehman, "Design and analysis of wind pump for wind conditions in Pakistan." *Advances in Mechanical Engineering*, vol. 11, no. 9, p. 168781401988040, 2019, doi: 10.1177/1687814019880405.
- [18] K. Z. Lin, T. T. Htay, and S. Y. Win, "Aerodynamic Analysis of Curved Blade for Water Pumping Windmill." *International Journal of Science and Engineering Applications*, vol. 7, no. 9, pp. 307-312, 2018, doi: 10.7753/ijsea0709.1012.
- [19] K. H. Karim and S. H. Ahmad, "Structural analysis of the Azmir – Goizha anticline, north and northeast of Sulaimani city, Kurdistan Region, Northeast Iraq." *Journal of Zankoy Sulaimani - Part A*, vol. 16, no. 1, pp. 45-68, 2014, doi: 10.17656/jzs.10284.

- [20] R. A. Kishore, T. Coudron, and S. Priya, "Small-scale wind energy portable turbine (SWEPT)." *Journal of Wind Engineering and Industrial Aerodynamics*, vol. 116, pp. 21-31, 2013, doi: 10.1016/j.jweia.2013.01.010.
- [21] V. B. Nguyen and D. Rozehnal, "Determination of performance parameters of vertical axis wind turbines in wind tunnel." *MATEC Web of Conferences*, vol. 107, p. 00076, 2017, doi: 10.1051/mateconf/201710700076.
- [22] K. Rogowski, M. O. L. Hansen, and G. Bangga, "Performance Analysis of a H-Darrieus Wind Turbine for a Series of 4-Digit NACA Airfoils." *Energies*, vol. 13, no. 12, p. 3196, 2020, doi: 10.3390/en13123196.
- [23] V. Patel, "The Wind Turbine Operated Water Pump." *International Journal for Research in Applied Science and Engineering Technology*, vol. 9, no. 4, pp. 1145-1156, 2021, doi: 10.22214/ijraset.2021.33874.
- [24] T. Luna, J. Ribau, D. Figueiredo, and R. Alves, "Improving energy efficiency in water supply systems with pump scheduling optimization." *Journal of Cleaner Production*, vol. 213, pp. 342-356, 2019, doi: 10.1016/j.jclepro.2018.12.190.